

Corbeau 5T : NEW MILLS HEAVY-DUTY WALL BRACKET

Corbeau 5-T is a heavy-duty wall bracket designed to support heavy load, up to 50 kN.



Designation	Code	Weight
Corbeau 5T	080460-9	15 kg / 33.1 lbs

SWL SLS 50 kN.

Hot-dip galvanised.

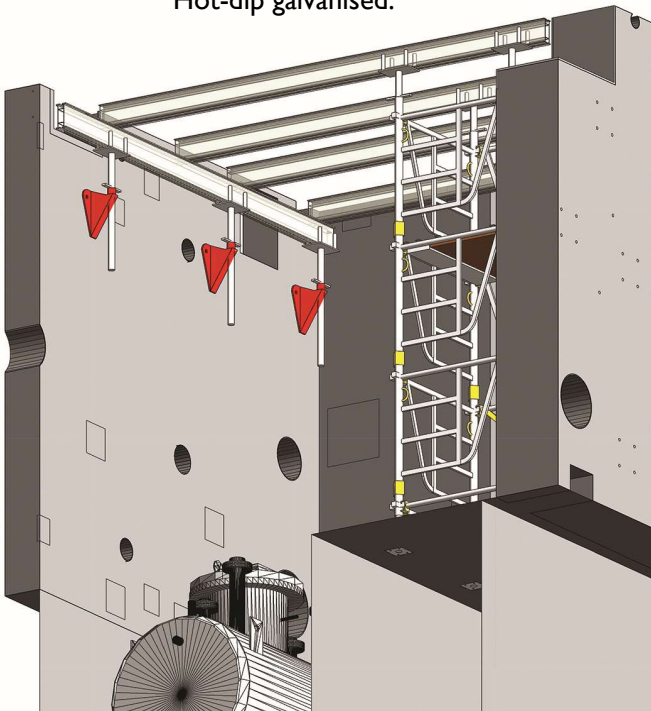

A beam parallel to the wall can be used to optimize the brackets number and to allow higher tolerances during the assembly.

Compatibility with MILLS falsework equipment

The wall bracket is compatible with all Mills's shoring adjustable heads.

Anchors

Maximum reactions SLS per anchor bolt :

- Shear : 2765 daN.
- Traction : 2260 daN

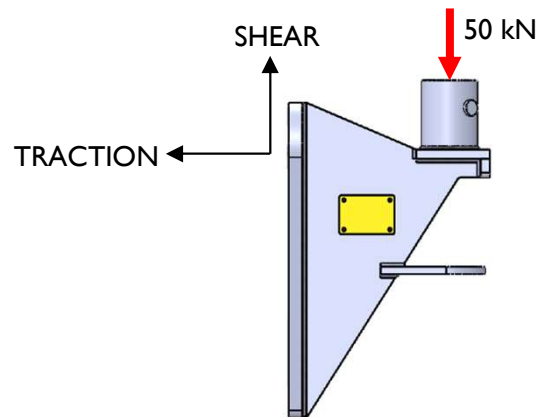

Dimensions and holes position (in mm)

